



Magna Mixer

Mixing Solutions serving your needs since 1904

11180 Southland Rd., Cincinnati, OH 45240 | 513.851.6900 | MagnaMixer.com

Handy "V" Cookie Depositor

The Handy "V" cookie depositor is designed to produce dozens of wire-cut uniform cookies accurately and efficiently.

PRODUCTION

Generates up to 1750 dozen wire-cut uniform cookies per hour, depending upon choice of die and machine.

VARIABLE SPEED CONTROLLER

Handy "V" has 2 variable speed controllers; one for controlling pan speed & product spacing and the other for controlling the feed rolls for dough feed, giving you up to 70 strokes per minute.

CONTINUOUS VARIABLE SPEED FEED ROLLS

Direct drive for heavy dough and large cookies.

SANITARY & ECONOMICAL

Easy to dismantle and reassemble stainless steel dough hopper, and stainless steel hinged fold down tables make



Over 400 Dies
to choose from;
including, different
shapes and sizes
for every holiday,
season, or occasion.





Magna Mixer

Mixing Solutions serving your needs since 1904

11180 Southland Rd., Cincinnati, OH 45240 | 513.851.6900 | MagnaMixer.com

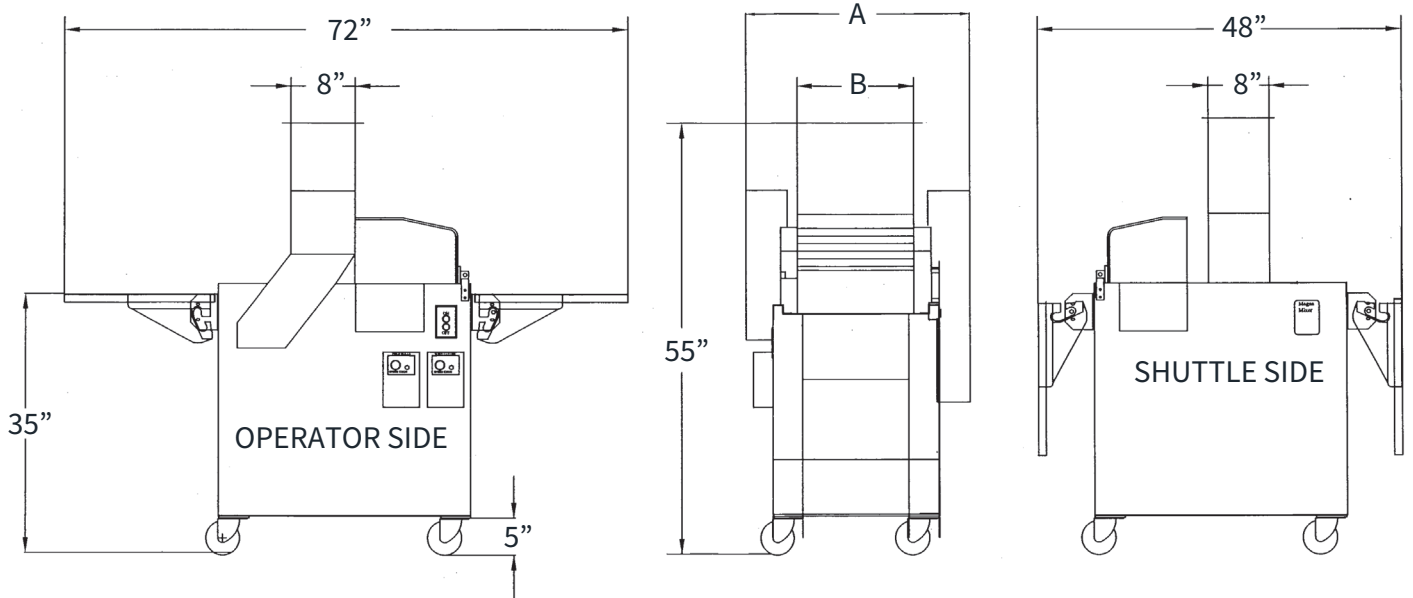

MACHINE SIZE	ELECTRICAL REQUIREMENTS	A	B	Shipping Weight
17"	115V, 1Ph, 60Hz, 10 AMP.	32"	15 1/2"	550lbs.
24"	115V, 1Ph, 60Hz, 15 AMP.	40"	23 1/2"	850lbs.



CONSTRUCTION The frame is made of heavy gauge stainless steel formed and welded into body construction. The hopper and the hinged fold-down tables are made from stainless steel.

PAN GUIDE The 17" machine is adjustable for 16" to 19" wide pans, and the 24" machine is adjustable for 24" to 27" wide pans.

FEED Continuous feed rolls allow uniform feeding of your product

CONVEYOR Variable intermittent conveyor belt with 1½" to 4½" spacing available

DRIVE Silent V-belt with anti-friction bearings

LUBRICATION Pressure grease alemite fittings

